

# Automobile LCD

Model # W07T740-AMA2

## Features:

- For In-Car Computing, PC, Server, GPS, and various VGA Use
- High Brightness, High Contrast LCD Panel
- VGA Input (15 pin D-SUB) x 1
- Composite Video Input (RCA connector) x 2
- Audio Input
- Built-in Speaker
- NTSC / PAL Multi-System
- Auto detects signal resolution
- Adjustable backlight level for night-time use
- Last Input memory
- Last Power setting memory
- IR Remote Control
- Automatic display adjustment
- On Screen Display Control
- Image Flip (VGA and Video Modes)
- 20-Pin heavy-duty connector
- "E" Mark Certified for Automotive use
- Support Max.36V Spike protection
- Composite one can be set to video signal input or power on/off control signal input by DIP switch
- 4-wire resistive Touch Screen (Optional)
- TR for sunlight readable (Optional)



FRONT VIEW

BACK VIEW

## Mechanical Design Drawings

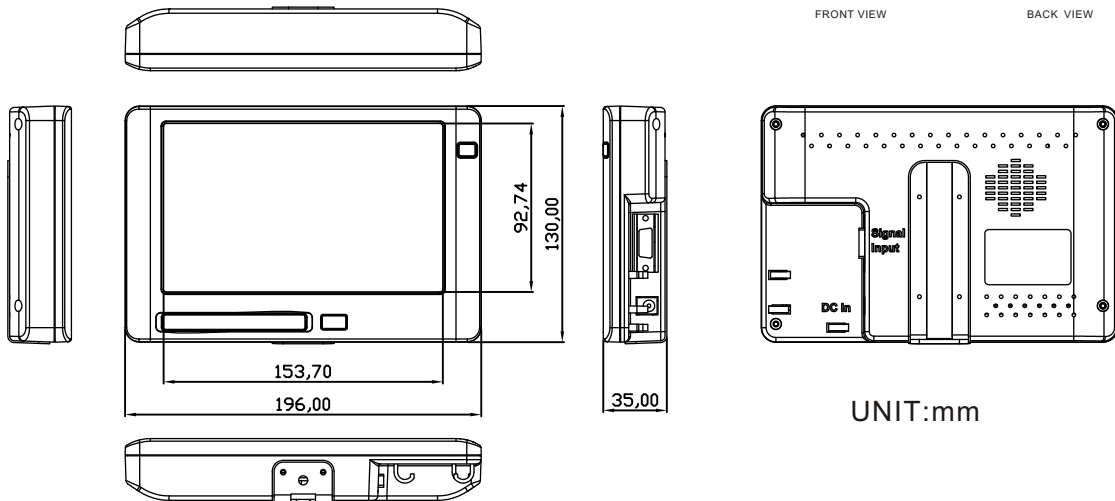

### Display Specification

- |                                   |                           |
|-----------------------------------|---------------------------|
| ■ Screen Size                     | : 7" (16:9)               |
| ■ Active Display Area (mm)        | : 152.4 (H) x 91.44 (V)   |
| ■ Pixel Pitch (mm)                | : 0.1905 (H) x 0.1905 (V) |
| ■ Display Resolution (pixel)      | : 800x480                 |
| ■ Brightness (CD/m <sup>2</sup> ) | : 350                     |
| ■ Contrast Ratio                  | : 300:1                   |
| ■ Viewing Angles (CR >=10)        | : -60,60(H); -60,40(V)    |
| ■ Supported Resolution            | : Max. to 1600*1200@60Hz  |
| ■ Recommended Resolution          | : 800x480@60Hz            |
| ■ Touch (Optional)                | : 4W Resistive (USB)      |

### Power Management

- |                     |                                 |
|---------------------|---------------------------------|
| ■ Operating Voltage | : DC 12V                        |
| ■ Power Consumption | : 8 W typical, normal operation |

### I/O Connector

- |  |                                       |
|--|---------------------------------------|
| 20-Pin heavy-duty connector (Complex lockable connector) |                                       |
| ■ VGA Input  | : 15 pin D-Sub x 1                    |
| ■ Video Input  | : Composite RCA x 2                   |
| ■ Audio Input / Built-in Speaker                         | : Stereo audio in via RCA/ 1W Speaker |

### Mechanical and Environment

- |                         |                                  |
|-------------------------|----------------------------------|
| ■ Dimension             | : 196*130*35mm                   |
| ■ Weight                | : 560g                           |
| ■ Operating Temperature | : -10~55 Celsius                 |
| ■ Storage Temperature   | : -30~85 Celsius                 |
| ■ Certification         | : UL, FCC, CE, E13 Certification |
| ■ ROHS Compliant        | : YES                            |