

News

- ▶ News
- ▶ Events
- ▶ RSS

AFL-F08A

8" Flat-Bezel Panel PC

Date: February 09, 2010

IEI Technology Corp.
 Tel: +886-2-8691-6798
 FAX: +886-2-6616-0029
 Email: sales@ieiworld.com

IEI Technology USA
 Tel: 1-909-595-2819
 FAX: 1-909-595-2816
 Email: sales@usa.ieiworld.com

IEI Technology China
 Tel: +86-21-3462-7799
 FAX: +86-021-3462-7797
 Email: sales@ieiworld.com.cn

IEI

Industrial Computer Leader
Provides you innovative & reliable total solution.

www.ieiworld.com

AFL-F08A Flat-Bezel

8" Flat-Bezel Panel PC

The new 8" panel is a full-flat surface touchscreen PC. The AFL-F08A includes all necessary input/output interfaces to control any subsystem or automation hardware in your office, business, or home. The new stylish design is easily integrated into any environment. The front panel is IP64 compliant. An optional projected capacitive touchscreen provides a multi-touch interactive user experience.

Features

- 8.0" LED TFT-LCD with stylish flat-bezel touchscreen
- Optional projected capacitive touchscreen supports multitouch
- Fanless system with Intel® Atom™ Processor N270 (512K Cache, 1.60 GHz, 533 MHz FSB)
- Hot keys controlled by cap-senscr in the front panel
- Optional color change kit matches the style of any decoration
- Wireless WI-FI LAN 802.11 b/g
- Integrated Bluetooth 2.0 module
- Build-in 300K pixel CMOS camera with low-light capability
- Two 1.5W speakers and microphone for multimedia applications
- IP64 compliant front panel
- IEI One Key Recovery solution allows you to create rapid OS backup and recovery (Suggest over 4GB storage capacity)



- [Specifications](#)
- [Dimensions](#)
- [Ordering Information](#)
- [Options](#)
- [Packing List](#)
- [Full-flat Surface Touchscreen](#)
- [Projected Capacitive Touch sensor](#)
- [Multimedia Hardware Device Ready](#)
- [Picture Frame In-Wall Mount](#)
- [Versatile I/O Ports](#)
- [More...](#)

Full-flat Surface Touchscreen

The AFL-F08A flat-bezel design covers the entire front frame (bezel) of standard LCD to make the screen and bezel appear to blend together. The seamless flat-bezel touchscreen system offers a stylish and easy to clean surface.

- Better visual effects
- No edge effects
- Sleek and stylish
- Easy to clean



Applications:



OFFICE

LIVING ROOM

YACHTING



KITCHEN

AUTOMATION

MUSEUM

Projected Capacitive Touch sensor (For Option)

Windows 7 with Multi-touch Capable

The AFL-F08A comes with the true multi-touch applications in support of the Microsoft Windows 7 operating system. Windows 7 features improved touch and gesture support. With Windows 7, handwriting recognition is faster, more accurate, and supports more languages.



Intuitive Multi-Touch Control



7H Anti-scratch Surface

Projected Capacitive touch technology utilizes a durable glass front surface. 7H hardness is stronger than the conventional touch panel and therefore is able to protect the screen from damage.



AR/AG Optical Coating

Special AR coating (anti-reflection) and AG coating (anti-glare) on the touch panel are engineered to reduce reflection and increase transmission of light to produce a better image.

Reduced reflected light
No image distortion



▲TOP

Multimedia Hardware Device Ready

Integrated webcam on the Panel PC, including a native 300K pixel; low-light function, and 30fps at VGA, is best suited for small-to-medium sized meetings and conferences held in facilities like local government councils, hotel conference rooms, training and educational venues and company boardrooms without external device installation.



Webcam Specifications

- VGA resolution image sensor
- Video resolution: 640x480, 352x288, 320x240, 176x144, 160x120.
- Frame rate: 640x480@ 30fps max.
- Storage Format of Image: AVI
- Storage Format of Photograph: BMP, JPEG



VGA CMOS Camera

- Auto white balance
- Auto exposure
- Auto compensation
- Focus range of 25 cm to Infinity
- Flip Control Option



▲TOP

Picture Frame In-Wall Mount

This optional kit includes a decorative front plate and wall mount enclosure to securely house the the AFL-F08A panel PC. The enclosure includes knockouts for power and I/O interface cables.



Decorative front plate
In-Wall Enclosure

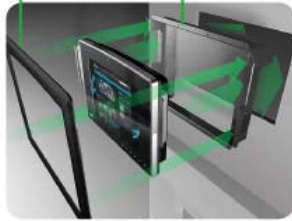

• Optional Decorative Kit:

DIM.
300mm x 230mm x 3.7mm

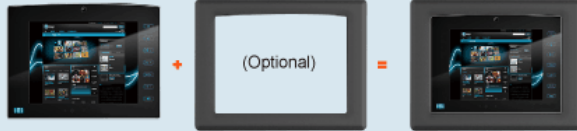

▲ TOP

Versatile I/O Ports

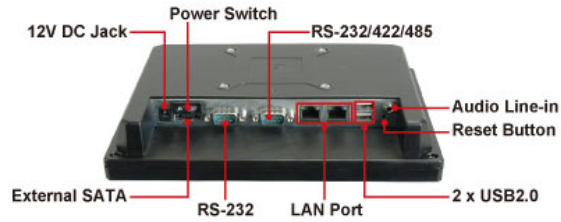

▲ TOP

Dimensions (Unit: mm)

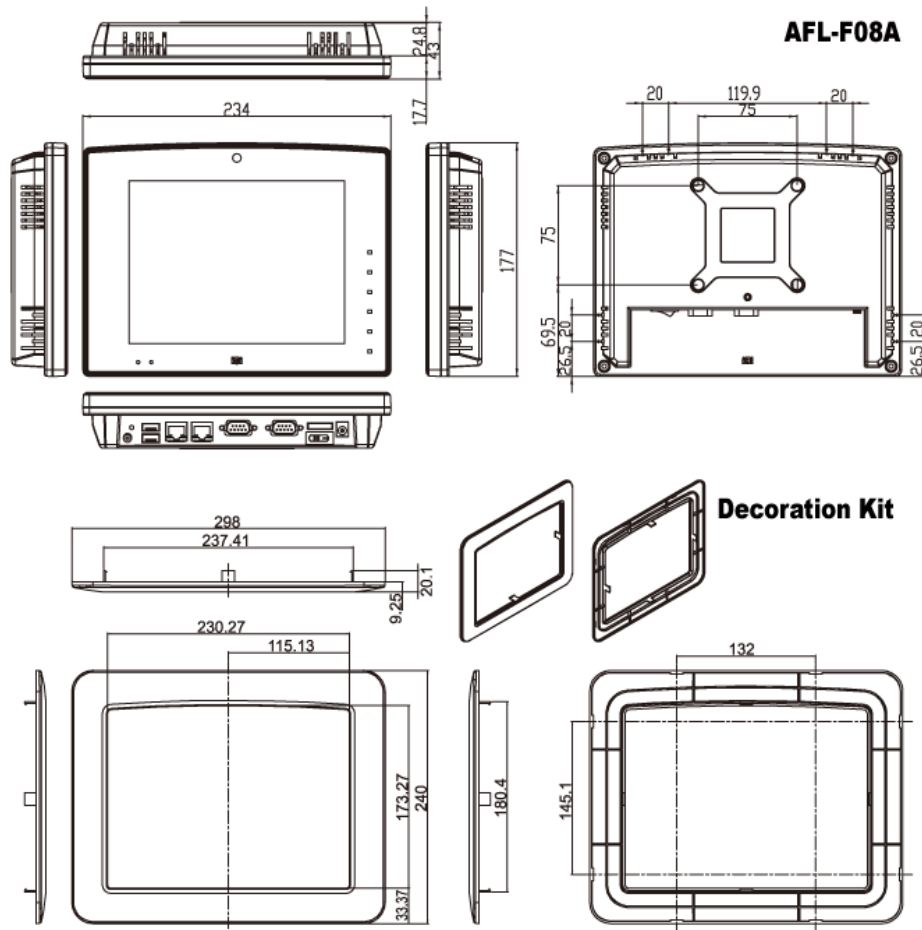

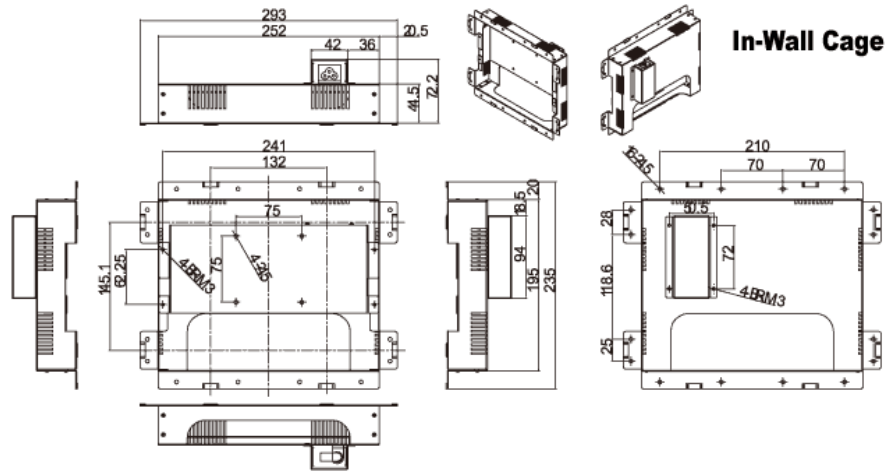

▲TOP

Specifications

Model	AFL-F08A-N270 
LCD Size	8"
Max Resolution	800 x 600
Brightness (cd/m²)	250
Contrast Ratio	500:1
LCD Color	262K
Pixel Pitch (mm)	0.2025(H) x 0.2025(V)
Viewing Angle (H-V)	140° / 130°
Backlight MTBF	30000 hrs (LED)
SBC Model	AFLMB-945GSE-N270-R10
CPU	Intel® Atom™ Processor N270 (512K Cache, 1.60 GHz, 533 MHz FSB)
Chipset	Intel® 945GSE + ICH7M
RAM	Supports one 400MHz or 533MHz DDR2 SO-DIMM (2GB Max.)
I/O Ports	1 x RS-232 COM Port 1 x RS-232/422/485 COM port 2 x RJ-45 for Giga LAN 2 x USB 2.0 1 x Power Switch 1 x Reset Button 1 x Audio Port (line-out) 1 x 12V DC Power Jack 1 x External SATA
SSD	CF TypeII
Watchdog Timer	Software programmable supports 1~255 sec. System reset
Audio	AMP 1.5W + 1.5W (internal speaker)
Expansion	1 x Wireless Lan 802.11 b/g Module (internal Mini PCIe interface) 1 x Bluetooth V2.0 (internal USB interface) 300K pixel webcam
Hot Keys	LCD On/Off, Brightness Up/Down, Volume High/Low by Cap-Sensor
Mounting	In-Wall, Panel, Wall, Stand and Arm VESA 75mm x 75mm
Color	Black
Dimensions (WxHxD) (mm)	234 x 177 x 43
Operation Temperature (°C)	-10°C ~ 50°C
Storage Temperature (°C)	-20°C ~ 60°C
N/G Weight	1.8Kg
IP Level	IP64 Front Panel
Safety & EMC	CE / FCC / CB / CCC
Touch Screen	Resistive Type 5-Wire (Touch controller IC is on board) or Projective Capacitive type touch screen
Power Adapter	63000-FSP036RAB608-RS 48W Power Adapter Input: 90VAC~264VAC, 50/60Hz Output: 12VDC
Power Requirement	12VDC
Power Consumption	32W

Note: WiFi 802.11 draft N is upgradable.

▲TOP

Ordering Information

	Part Number	Description
Resistive Touch Panel	AFL-F08A-N270/R/1G-R10	8.0" 250cd/m ² SVGA Fanless panel PC with Intel® Atom™ N270 1.6GHz CPU, 1GB DDR2 RAM, 802.11 b/g WiFi, touch screen, Bluetooth, 300K camera, microphone, RoHS

Projected
Capacitive Touch Panel **AFL-F08A-N270/PC/1G-R10**

8.0" 250cd/m² SVGA Fanless panel PC with Intel® Atom™ N270
 1.6GHz CPU, 1GB DDR2 RAM, 802.11 b/g WiFi, Projective capacitive
 touch screen, Bluetooth, 300K camera, microphone, RoHS

[▲TOP](#)

Options

Item	Model	Item	Model
Panel mounting kit	AFLPK-12	OS: Win XPE (1 GB CF card)	AFLCF-F08-N270-XPE-R10
Wall mounting kit	AFLWK-12	OS: LINUX (2 GB CF card)	AFLCF-F08-N270-LNX-R10
Rack mounting kit	AFLRK-08	Hybrid Card Reader	AFLP-08AMSI-U
ARM	ARM-11-RS / ARM-31-RS	Magnetic Stripe Reader	AFLP-08AMSR-U
Stand	STAND-A08 / STAND-100-RS	DC 12V Input UPS	AUPS-A10-R10 (7.4V 3800mAH)
VSTAND	VSTAND-A10	DC 9~36V Input UPS	AUPS-A20-R10 (7.4V 3800mAH)
9~30VDC to 12VDC converter module	IDD-930160-KIT	Note: OS image only support single touch	
OS: Win CE 6.0 (128 MB CF card)	AFLCF-F08-N270-CE060-R10		

[▲TOP](#)

Packing List

Item	P/N	Q'ty	Specifications
Screws Pack	44013-030041-RS	4	M3; 5mm
Power Adapater	63000-FSP036RAB608-RS	1	90~264V AC; 12V DC; 36W
Power Cord	32000-000002-RS	1	1750mm; European Standard (EU or US, Which type of cord is shipped depends on the shipment country)
Utilities CD	7B000-000087-RS	1	
Touch Pen	XTR104-0002-RS	1	

[▲TOP](#)

Taiwan
IEI Technology Corp.

TEL : 886-2-8691-6798
 FAX : 886-2-6616-0028
 Email: sales@ieiworld.com
 http://www.ieiworld.com

U.S.A
IEI Technology USA Corp.

TEL : +1-909-595-2819
 FAX : +1-909-595-2816
 Email: sales@usa.ieiworld.com
 http://www.ieiworld.com/

China
IEI Technology SH Corp.

TEL : 86-21-3462-7799
 FAX : 86-21-3462-7798
 E-mail:sales@ieiworld.com.cn
 http://www.ieiworld.com.cn

Copyright© 2010; IEI Technology Corp. All rights reserved.
 Design and specifications are subject to change without prior notice.

Member of ICP Group 

I don't want to receive this news again